

# **R W KNIGHT & SON**

**A FAMILY STOVE  
& HEATING BUSINESS EST.1974**

R Twin Wall Insulated Flue



**For wood, multi fuel, oil & gas appliances**

# Stainless Steel Chimney System



## Product Benefits



INTERNAL & EXTERNAL  
APPLICATIONS

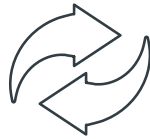

TWIST LOCK  
JOINTING SYSTEM



FAST & EASY  
INSTALLATION



RAPID FLUE GAS  
TEMPERATURE  
STABILISATION



2 HOUR FIRE RATING

# Safety Quality Efficiency

Twin wall residential flue.

The product is a CE marked chimney system, designed to meet requirements for multi-fuel appliances operating under negative or non-condensing conditions.

The fully welded construction, combined with a high performance insulating medium, provides the optimum level of performance for both DEFRA approved and the latest EcoDesign high-efficiency stoves, in addition to both modern and traditional appliances.

Fixing packs are included with any components that require fixings.

### Sizes Available

- 127mm (5 inch)
- 152mm (6 inch)
- 178mm (7 inch)
- 203mm (8 inch)

# Internal & External Installation Examples

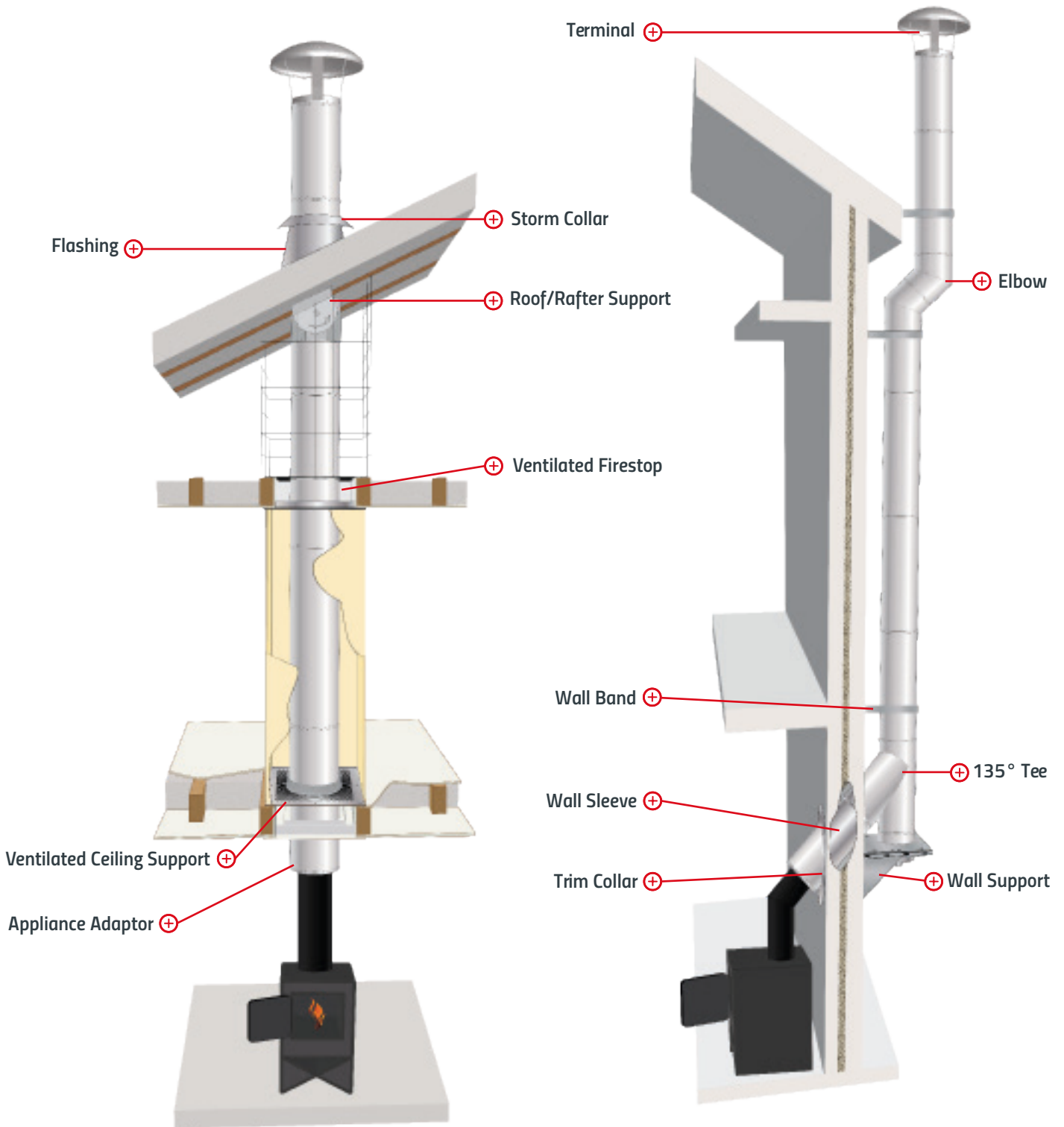

# Technical Specification

## Chimney Designations to BS EN 1856-1

2797-CPR-496040	⊕ Licensing Code
BS EN 1856-1	⊕ British Standard
T450	⊕ Temperature Class-Up to 450°C
N1	⊕ Pressure Class-Negative to 40 Pa
D	⊕ Condense Resistance-Dry only
Vm	⊕ Corrosion Class-Rating declared by manufacturer
L50040	⊕ Material Specification-316L 0.4mm thickness
G(50)	⊕ Soot fire Resistance-Resistant, 50mm clearance to combustibles

### Twist-Lock Jointing System

The system utilises an eight-barb twist lock jointing system to secure each joint. The components are secured by engaging the barbs with a firm twist of each section, and then finished with a locking band. The joint design facilitates a maximum unsupported height above the last support of up to 1.5 metres. A locking band is provided with all female components.

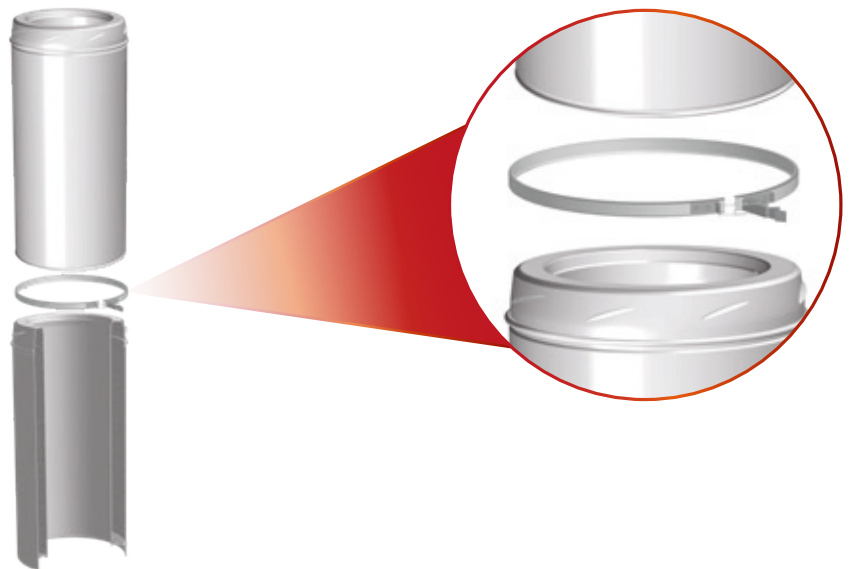

### Construction

The product is manufactured from a high grade 316L stainless steel liner and a 304 outer case. The unique joint design allows the inner liner to freely expand and contract throughout the system as the flue gas temperature varies, eliminating the need for additional expansion components.

### Insulation Properties

The product utilises a high performance mineral wool, which is auger injected into a 25mm annulus between the inner and the outer. A mean insulation density of 250kg/m<sup>3</sup> offers rapid stabilisation of draught and excellent thermal performance. The insulation properties achieve a 50mm distance to combustibles and a 2 hour fire rating.



## Straight Length

Available in nominal installed lengths of 120mm, 300mm, 500mm, 1000mm.

	120mm	300mm	500mm	1000mm
∅	Code	Code	Code	Code
127mm	2110605	2141105	2141005	2140905
152mm	2110606	2141106	2141006	2140906

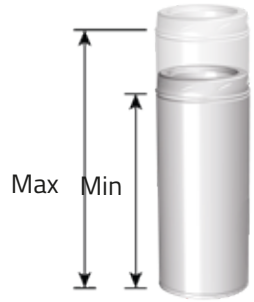

## Adjustable Length

The telescopic adjustable length offers a degree of flexibility when standard length dimensions are not suitable. All adjustable lengths are supplied with separate insulating material for insertion into the annulus once the installed length has been determined. Includes a clamp band as standard.

∅	Short Adjustable Length			Long Adjustable Length		
	Min	Max	Code	Min	Max	Code
127mm	200	325	2144005	350	530	2141205
152mm	200	325	2144006	350	530	2141206

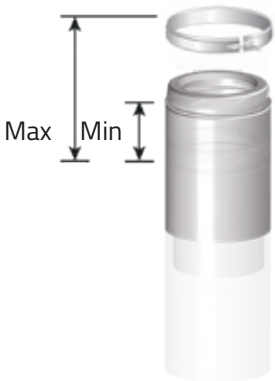

## Adjustable Slip Section

Designed to fit over any standard length and offers a degree of flexibility when standard dimensions are not suitable. Bottom length **not** included. Supplied with separate insulation and a clamp band. **Only to be used to extend standard lengths.**

∅	Min(mm)	Max(mm)	Code
127mm	30	256	2143005
152mm	30	244	2143006

The adjustable components above are not load bearing, always use a support component directly above when vertically applied.

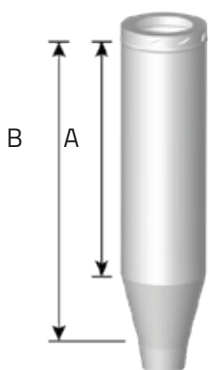

## Tapered Adaptor Length

Offers an aesthetic transition from single wall connecting flue pipe to Rflue.

∅	A(mm)	B(mm)	Code
127mm	865	1015	2140405
152mm	865	1015	2140406

This component should only be fitted to a single wall connecting flue pipe, and not directly to the appliance.

## 2 Segment Elbows (15° / 30° / 45°)

Provides a change of direction, measured from the vertical by the specified angle. Elbows are supplied with an un-barbed female coupler (to allow for 360° rotations) and bolted locking band for rigid joint bracing, especially when used as an offset around gutters and fascia boards.

Angle	15°	30°	45°
∅	Code	Code	Code
127mm	2131405	2132305	2132205
152mm	2131406	2132306	2132206



# Tees & Tee Components

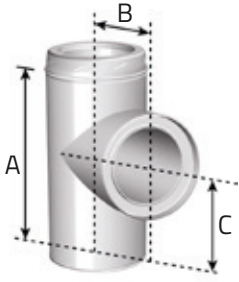

## 90° Equal Tee

Used at the base of a vertical chimney from a horizontal stove outlet, or as an inspection opening.

∅	A(mm)	B(mm)	C(mm)	Code
127mm	305	152	152	2114305
152mm	325	162	162	2114306

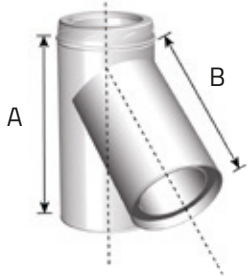
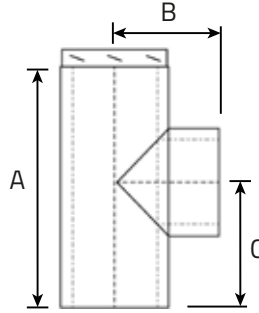

## 135° Tee

Used at the base of a vertical chimney, or to allow a smooth transition from the horizontal to vertical plain when used with a 45° elbow. The coupler on the branch is unbarbed to allow unlimited rotational adjustment and includes a bolted locking band.

### Dimension (mm) With 45° Elbow

∅	A(mm)	B(mm)	C(mm)	D(mm)	Code
127mm	495	340	388	38	2141305
152mm	495	375	422	45	2141306

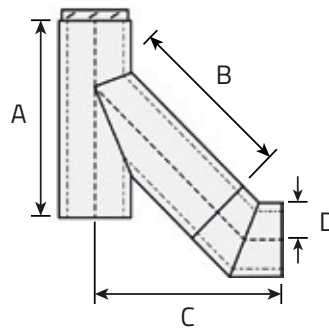

## Tee Cap with Drain

Used at the bottom of a vertical chimney to facilitate drainage and cleaning. Fitted with a stainless steel 1" BSP external thread drain connection.

∅	Code
127mm	2153205
152mm	2153206



## Tee Cap

Used to close off the branch or base of a tee, or for use as an access/inspection/cleaning component.

∅	Code
127mm	2119105
152mm	2119106

# Floor Penetration & Firestop Components

## Combustible floors - solid fuel and oil fired appliance's (T450)

The following components must be used when the product is fitted to a solid fuel or oil fired appliance, when the flue gas temperature will not exceed 450°C, and/or where the chimney system penetrates a combustible floor. Each ventilated component offers a 50mm distance to combustible materials.

**Intumescent Sealant (1099900) is required for the correct installation of ventilated components**

### D5 White Ventilated Ceiling Support Kit (T450)

Used to both support and firestop the chimney system when it passes through the first combustible floor, directly above the appliance. The support component incorporates a patented intumescent matrix design which expands rapidly with temperature and seals the plate to prevent the potential spread of fire or smoke from the room below. The D5 offers an aesthetically pleasing flat appearance where the chimney passes through the ceiling penetration and uses minimal ventilation openings. This component is finished in a high quality white gloss finish.

ø	A(mm)	B(mm)	Code
127mm	352	279	2188805
152mm	372	299	2188806

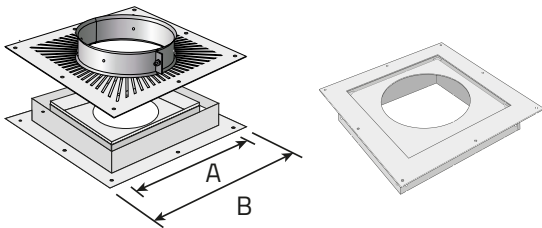

### Ventilated Firestop (T450)

Used where the chimney passes through the upper combustible floors, and where sections below the floor are enclosed within a non-combustible shaft. This item is not load-bearing.

ø	A(mm)	B(mm)	Code
127mm	379	281	2188705
152mm	399	301	2188706

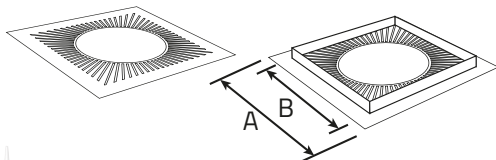

### Intumescent Sealant

Required for the correct installation of the Ventilated Ceiling Support Kits & Firestops

Code
290ml 0199900



## Non-combustible floors

The following components can be used on appliances where the flue gas temperature does not exceed 250°C, and/or where the chimney passes through a non-combustible floor.

### Ceiling Support

Provides a 50mm air gap clearance to a penetrated floor or ceiling and is only used where the product penetrates a non-combustible floor, and/or services a gas or oil fired appliance where the flue gas temperature does not exceed 250°C.

ø	A(mm)	B(mm)	Code
127mm	330	280	2102705
152mm	355	305	2102706

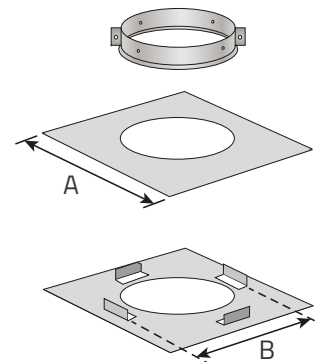

### Firestop Spacer

Used to provide location, fire and dust stopping where the chimney is used through non-combustible floors, and/or services an appliance where the flue gas temperatures does not exceed 250°C. This item is not load bearing.

ø	A(mm)	B(mm)	Code
127mm	330	280	2108705
152mm	355	305	2108706

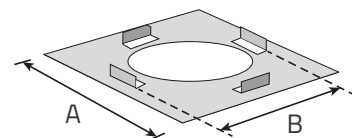

Upper floor  
(Ventilated Firestop)

First floor  
(Ventilated Ceiling Support)

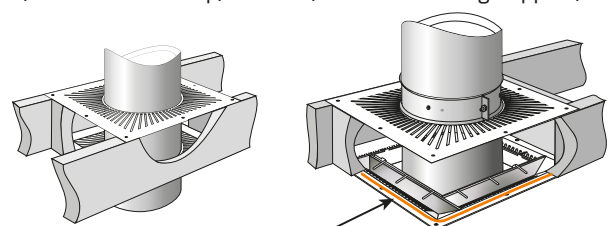

Apply a bead of intumescent sealant around the flange.

# Support Components

## Wall Band

Wall bands provide lateral support for the chimney and must be used at intervals not exceeding 3.0 metres beyond any load bearing support.

∅	A(mm)	Code(S/S)	Code(Galv)
127mm	137	3115155	3116155
152mm	162	3115205	3116205

## Wall Band Extension Pieces

Where externally applied, the intervals between Wall Band fixing centres must be reduced from 3.0 metres to 2.5 metres. The maximum clearance is as detailed below. Available in both stainless steel and galvanised steel.

∅	Min	Max	Code(S/S)	Code(Galv)
All	50	100	3119136	3120136

## Heavy Duty Wall Band (S/S)

Can also be used as a conventional wall band.

∅	A(mm)	B(mm)	Code
127mm	250	112.5	3109512
152mm	270	126	3109515

## Extension Brackets (S/S)

Size	A(mm)	Code
Short	324	31093ST
Medium	395	31093MD
Long	600	31093LG

## Universal Roof/Rafter Support

As the Roof/Rafter Support above, but with a gimbal plate that is universal across all diameters. The gimbal plate is adjusted on site to match the diameter of the chimney.

Suits up to 600mm rafter span.

Each item consists of 2 supports.

∅	A(mm)	B(mm)	Code
All	203	220	7002900

## Support Length (Strut/Guy Attachment)

A 100mm installed length which incorporates a support plate located 33mm from the bottom edge and features slotted holes for rotational adjustment, for fixing to bespoke bracketry. This component also doubles as a strut / guy attachment length offering anchoring points to which guys, or preferably rigid stays can be secured using M8 nuts and bolts.

∅	A(mm)	B(mm)	Code
127mm	100	33	2171305
152mm	100	33	2171306

## Wall Support Bracket

Used to take the vertical load of the chimney when supported from a wall. The support bracket is fully adjustable allowing varying clearances from the wall (50mm-150mm). Requires M10 wall fixings.

**Support length included.**

**Stainless**

∅	A(mm)	B(mm)	C(mm)	Code
127mm	282	311	265	2151705
152mm	302	331	285	2151706

**Galvanised**

127mm	282	311	265	2151805
152mm	302	331	285	2151806

## Single Wall to Rflue Anchor Plate

Designed to be used when connecting to a lintel or pre-cast chamber. A short section of liner projects a nominal 150mm through the bottom of the plate. This component could also be used to connect a flexible liner on a capped chimney within the attic space.

**Maximum Load: 13m.**

∅	A(mm)	B(mm)	C(mm)	Code
127mm	123	400	350	2152705
152mm	148	400	350	2152706

## Bracing Bracket

A clamping collar for the attachment of struts/ supports.

∅	Code
127mm	2109205
152mm	2109206

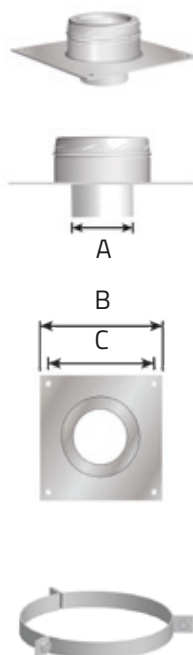
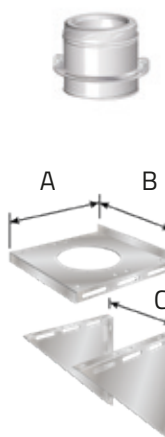



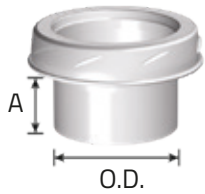

## Appliance Adaptor

Used to connect the appliance outlet to the Rflue chimney system. Also used to connect to single wall connecting flue pipe.

∅	A(mm)	O.D.	Code
127mm	36	123	2119405
152mm	36	148	2119406

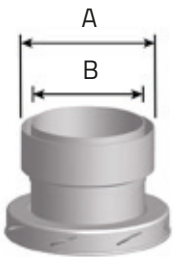

## Rflue to Flex Adaptor

Used to connect Rflue to a flexible flue liner.

∅	(I.D) (O.D)		Code
	A(mm)	B(mm)	
127mm	134	125	2150105
152mm	161	145	2150106



## Flex to Rflue Adaptor

Used to connect from a flexible flue liner to Rflue.

∅	A(mm)	B(mm)	Code
127mm	132.5	125	2150205
152mm	157.5	145	2150206



## Short Tapered Adaptor

Offers an aesthetic transition from the single wall connecting flue pipe to an Rflue chimney system.

∅	A(mm)	Code
127mm	150	2140505
152mm	150	2140506

**This component should only be fitted to a single wall connecting flue pipe, and not directly to the appliance.**

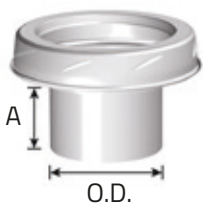

## Appliance Increaser Adaptor

Used to increase from the appliance outlet size by one diameter size.

∅	A(mm)	O.D.	Code
127mm	30	97	2119705
152mm	30	123	2119706

## Appliance Adaptor Installation

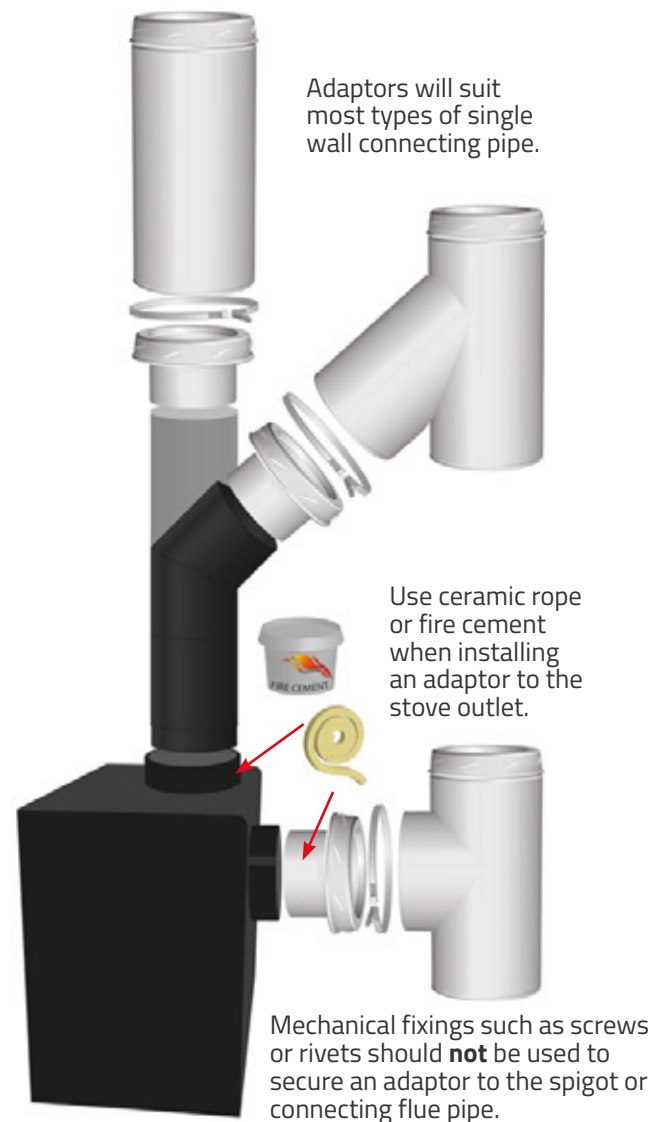

# Terminals

## Solid Fuel Chimney Termination Heights

Termination for solid fuel and oil are subject to EN 15287. The illustration below is for solid fuel. If the chimney serves an oil-fired pressure jet appliance, the chimney must discharge a minimum of 600mm above the roof penetration point, or any adjacent structure, if it is within 750mm. The chimney must also terminate at least 600mm from any opening into the building and 300mm from any combustible material. For domestic natural gas appliances, chimney termination heights are governed by BS EN 5440-1.

**Minimum distance measured from the top of the chimney construction, excluding any pot or terminal:**

- A** 2.3 metres horizontally clear of the roof surface, e.g. if the roof pitch is 45°, then the chimney should project 2.3 metres above it, **and:**
  - a) At least 1m above the highest point of intersection of the chimney and weather surface; or
  - b) At least as high as the ridge.
- B** 1.0 metre, provided A is satisfied, or 600mm above the ridge if G is less than 600mm.
- C** 1.0 metre above the top of any flat roof, and the top of any openable roof light, dormer window or ventilator, etc., if it is located within 2.3 metres.
- D/E** If D is less than 2.3 metres, E shall be not less than 600mm.
- F** 600mm above the ridge.
- G** If G is within 600mm of the ridge then B shall be 600mm above the ridge.

## Round Top

The Round Top offers strong protection against driving rain and wind, recommended for exposed locations. The new design features a barbed coupler and a step for easier installation.

∅	A(mm)	B(mm)	Code
127mm	255	234	2107505
152mm	300	234	2107506

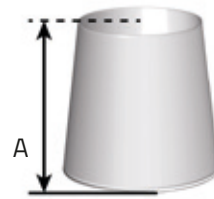
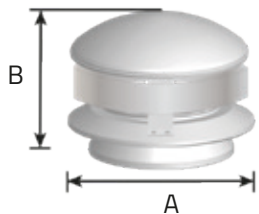

## Top Stub

The Top Stub offers the least resistance to flue gases and are ideal for solid fuel and oil fired appliances, providing there is drainage at the base of the chimney.

∅	A(mm)	Code
127mm	228	2117305
152mm	228	2117306

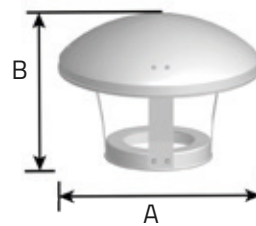

## Rain Cap

The Rain Cap offers a degree of protection from rain and is suitable for solid fuel and oil fired appliances.

∅	A(mm)	B(mm)	Code
127mm	255	155	2107405
152mm	300	155	2107406

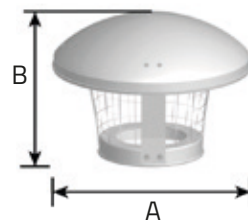

## Rain Cap with 1" Mesh

As the Rain Cap above, but with a mesh incorporated to protect from birds.

∅	A(mm)	B(mm)	Code
127mm	255	155	2107605
152mm	300	155	2107606

## Storm Cowl

The Storm Cowl is designed to offer maximum protection against driving rain and strong winds. Please note that this is not an anti-down draught terminal. For solid fuel applications, the Round Top would be recommended.

∅	A(mm)	B(mm)	Code
127mm	294	175	2148705
152mm	319	188	2148706

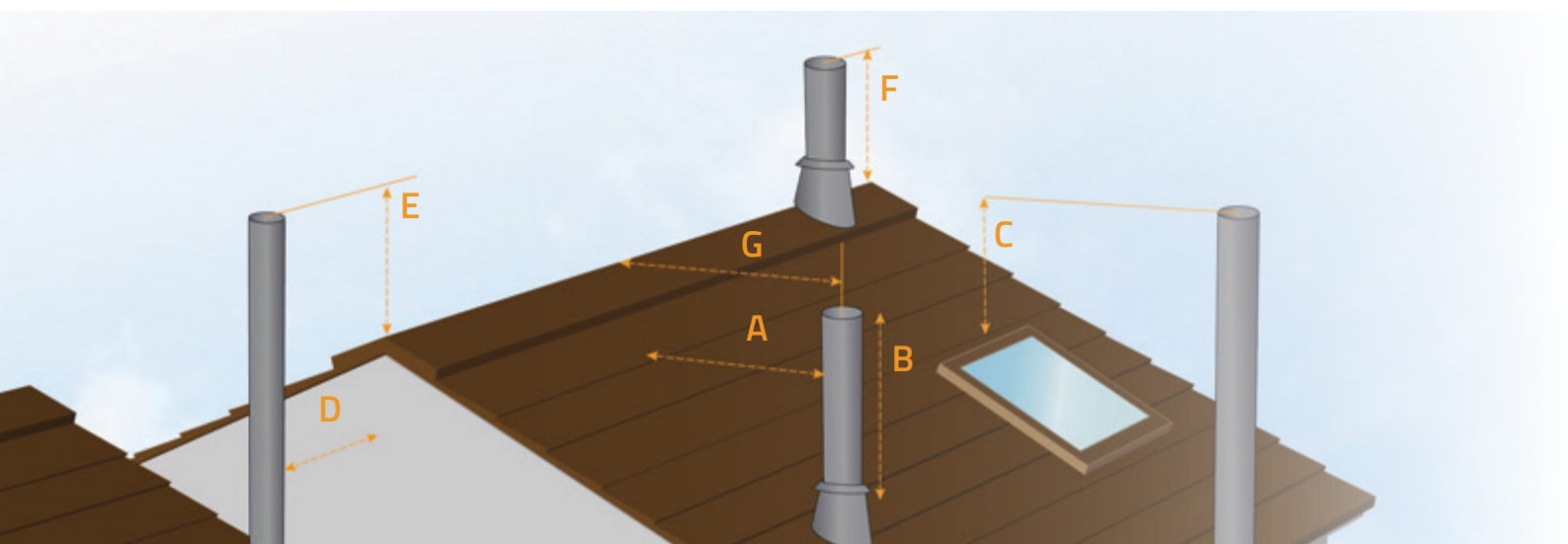
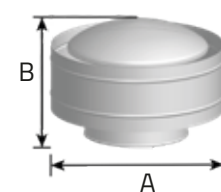

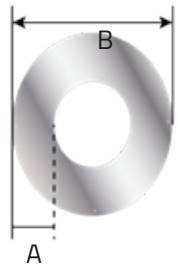

## 90° Trim Collar

This item is used to offer an aesthetic closing ring where a chimney passes through an outside wall. Manufactured from polished stainless steel.

∅	A(mm)	B(mm)	Code
127mm	108	394	2108505
152mm	103	409	2108506



## Sprung Locking Band

A locking band must be used on all joints and is included with each component that has a female coupler.

∅	Code
127mm	2108605
152mm	2108606

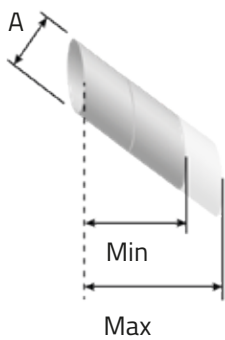

## 45° Adjustable Wall Sleeve

Must be used where a 135° tee is used to pass the chimney through an external masonry wall and provides a continuous, uninterrupted run through the wall. Provides clearance of 25mm as standard. Adjustable for a wall thickness of 200mm - 380mm.

Once extended, the joint must be secured with self-tapping screws and covered around the circumference with a heat resistant foil duct tape. Available in both stainless steel and galvanised steel.

**Not suitable for applications where the wall construction may contain combustible materials.**

### Stainless Steel (Masonry)

∅	A(mm)	Min	Max	Code
127mm	237	200	380	3107305
152mm	257	200	380	3107306

### Galvanised Steel (Masonry)

∅	A(mm)	Min	Max	Code
127mm	237	200	380	3107105
152mm	257	200	380	3107106



## Bolted Locking Band

A screw-toggle locking band is provided as standard with the unbarbed female coupler on elbows and 135° tee branches. Can be used to provide extra strength on a joint.

∅	Code
127mm	2108605MT
152mm	2108606MT



## Aluminium Storm Collar

Used to weather the top of the flashing. Supplied with a tube of silicon sealant.

∅	A(mm)	Code
127mm	50	70123407
152mm	50	70123409

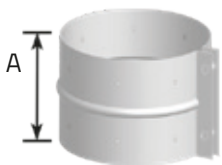

## Structural Locking Band

Required for added security on unsupported stacks up to 2.5m above the final support or wall band.

∅	A(mm)	Code
127mm	80	2159805
152mm	80	2159806

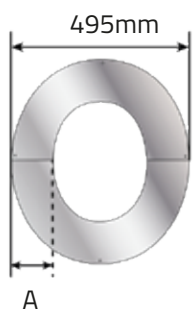

## Angled Wall Cover Ring (2-Piece)

Designed to offer an aesthetic trim around the chimney where it penetrates the wall at an angle. The component is available in 5 angle variations.

∅	A(mm)	0-10°	10-20°	20-30°	30-40°	40-50°
		Code	Code	Code	Code	Code
127mm	159	7071212	7071312	7070012	7070312	7070212
152mm	146.5	7071215	7071315	7070015	7070315	7070215

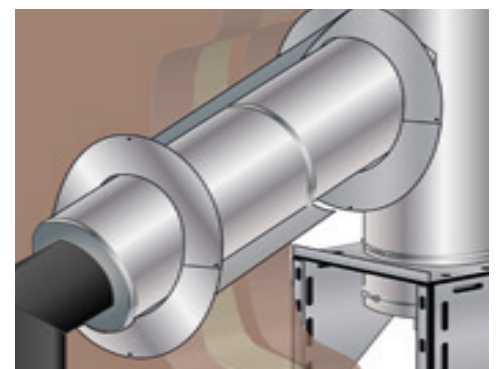

Angled Wall Cover Rings

# Installation Guidelines



## Approvals

Rflue has been assessed and CE marked to BS EN 1856-1.

The chimney system has also been assessed by the Loss Prevention Council for fire resistance. A fire resistance of two hours can be achieved in accordance with the stability and integrity criteria of BS 476: Part 20 for duct type B.

## Quality

All components are manufactured under a quality assurance scheme, certificate No. FM557622, administered by British Standards in accordance with BS EN 9001.

## Mandatory Requirements

The installation of a solid fuel appliance must be carried out by a member of a Competent Person Scheme, such as HETAS or through Local Authority Building Control (LABC) or one of their appointed inspectors, who will certify the installation. For oil and gas, connection to an appliance that is connected to a fuel supply must be carried out by a registered installer, e.g. OFTEC (Oil) / Gas Safe (Gas). For full design and installation details, the key referral documents are:

Approved Document J (England & Wales)

DFP Technical Booklet L (Northern Ireland)

Technical Handbook – Domestic (Scotland)

BS EN 15287 – Design, Installation and Commissioning of chimneys

BS EN 1443 – Chimneys – General Requirements

BS EN 13384-1 – Calculation methods single inlet chimneys

## Notice Plate

It is a requirement that a robust Notice Plate must be provided and indelibly marked, detailing the application and specific data relating to the installation. The Notice Plate should be securely fixed in an unobtrusive but obvious position within the building, such as:

- Next to electricity consumer unit
- Next to the chimney installation as described
- Next to the water supply stop-cock

## Joint Design and Construction

The joint is made by fitting the female end over the male end and engaging the joint system by rotating the component clockwise. A Locking Band is then fitted to finalise the joint.

The Rflue joint incorporates an eight barb twist lock coupler system to allow easy and rapid installation of the product. When used with the support components, the joint will support up to 1.5 metres free standing above the last support.



## Life Expectancy and Affecting Factors

Under normal operating conditions and with the correct servicing, the chimney will provide many years of service and is provided with a 15-year manufacturers defects warranty as detailed within our standard terms and conditions of sale. To ensure the optimum condition and longevity of the product, the following points must be observed:

- Chemical chimney cleaning products or the use of mild steel brushes and equipment **MUST** not be used to clean the chimney system.
- Cleaning / inspection of both the connecting flue pipe and chimney should be undertaken at least once a year, preferably twice a year, before and after the heating season. Particularly important when burning solid fuel.
- Use only approved solid fuels as listed in the HETAS Guide ([www.hetas.co.uk](http://www.hetas.co.uk))

**Note: Fuels containing petroleum coke or other such blends must not be used. Some smokeless fuels contain high levels of halogens and when the appliance is slumbered, may cause the formation of acidic compounds, leading to premature corrosion of the product. Corrosion is not considered a manufacturing defect and will invalidate the warranty.**

- It is important that the combustion air supply is chemically clean and not contaminated. For example, if the appliance is located near a chlorinated swimming pool.
- When the chimney is installed externally in coastal regions, the external casing must be adequately protected either with a painted or specialist coating to prevent localised corrosion. Galvanised component should not be used, always use stainless steel.
- As unseasoned virgin wood can contain up to 50% moisture, newly felled wood must be allowed to season until the moisture content reduces to around 20%. Failure to use well seasoned wood can increase the risk of deposits building in the liner, which is the main cause of chimney fires. Under no circumstances should chemically treated wood be used as the fuel source. When buying wood, look for the “Woodsure Ready to Burn” logo as a sign.
- Prolonged slumbering of the appliance is a contributing factor to system chimney failure. It is important to maintain a sufficiently high flue gas temperature to ensure complete combustion. Complete combustion prevents condensation that can lead to corrosion issues and the excessive build up of combustion deposits in the liner. Where the appliance has been slumbered, it is advisable to run the appliance at a controlled high fire condition for a period of at least 30 minutes afterwards.
- Multi-fuel appliances are designed to burn either seasoned virgin wood or approved solid fuels. Fuels should not be mixed as it increases the risk of deposits building up in the liner.

# Installation Guidelines

## Lateral Supports

Wall Bands and Heavy Duty Wall Bands are available for the lateral support of the installation. All Wall Bands offer 50mm clearance from the outer case of the flue. Optional Extension Brackets are available to increase this distance up to a maximum of 100mm. Heavy Duty Wall Bands are also available with Side Extension Brackets, available in three sizes.

## Adjustable Length & Slip Section

These components are supplied with an insulation pack. Depending on the required finished length of the component, additional insulation is added into the annulus. It is critical that care is taken when adding the insulation to ensure full integrity of the insulation throughout the length when installed. Where used as a disconnecter section directly above the appliance, any combustible material should be located at a distance of at least 1.5 x ID away from the component. Neither the Adjustable Length or Slip Section are load bearing, a Wall Support Assembly must be used immediately above when vertically applied.

## Roof/Rafter Support

A Roof/Rafter Support bracket is used where flue passes through the roof to termination. This component offers both lateral and vertical loading.

## Product Weights

Maximum weight per metre run installed, excluding support components.

Ø (mm)	127	152
kg/m	6.7	8.2

## Maximum Structural Considerations for Components

The table below details the maximum number of metres that can be supported by various components, it is imperative that these limitations are not exceeded. Where possible, components such as Inlet Tees and Inspection Lengths should not be vertically loaded, but suspended below a support component such as the Wall Support Assembly. Where this is unavoidable, refer to the maximum heights in the table below.

Components	Diameter (mm)	
	127	152
Inspection Length	13m	13m
Ceiling Support	6m	6m
Ventilated Ceiling Support	6m	6m
Anchor Plate	13m	13m
90° Tee	13m	13m
135° Tee	10m	10m

## Wall Support Bracket – Technical Information

### Support configuration and distance between brackets

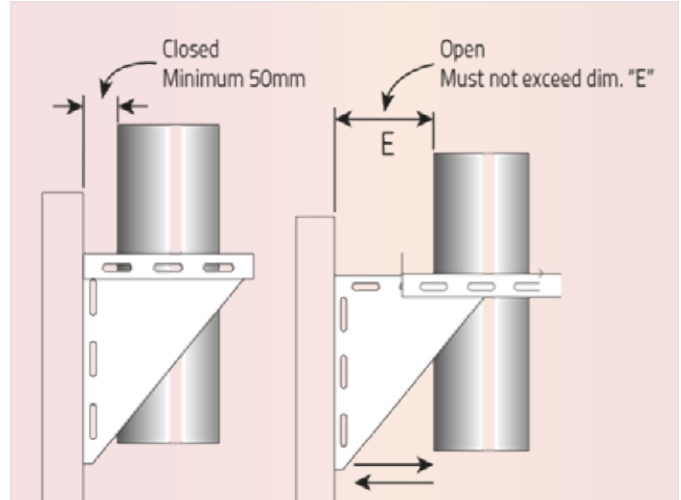

Ø (mm)	A (m)	B (m)	E (mm)
127	30	25	150
152	30	25	150

This table details the maximum distance in metres between wall supports, based on the support configuration below.

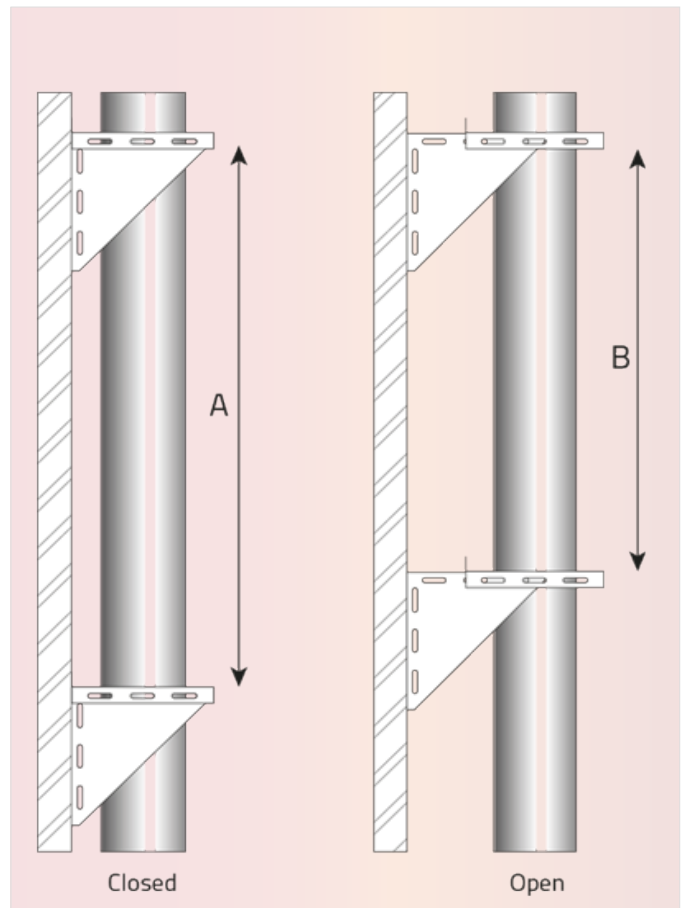

# Installation Guidelines

## External Installation

The illustration below shows a typical support arrangement for an external chimney. The vertical weight of the chimney is taken by a Wall Support Bracket. A removable Tee Cap with Drain (21532XX) is fitted to the underside of the Wall Support Bracket which can be removed for sweeping and inspection. Wall Bands (3115XXX) are then installed every 3.0 metres to provide lateral support. It is essential that adequate bracing is provided directly before and after an offset or change in direction. It is important that adequate fixings, such as M10 rawl bolts, are used throughout the chimney system to anchor support components to the structure. In all cases, the structure to which fixings are attached must be structurally sound and capable of taking the required loadings of the support components.

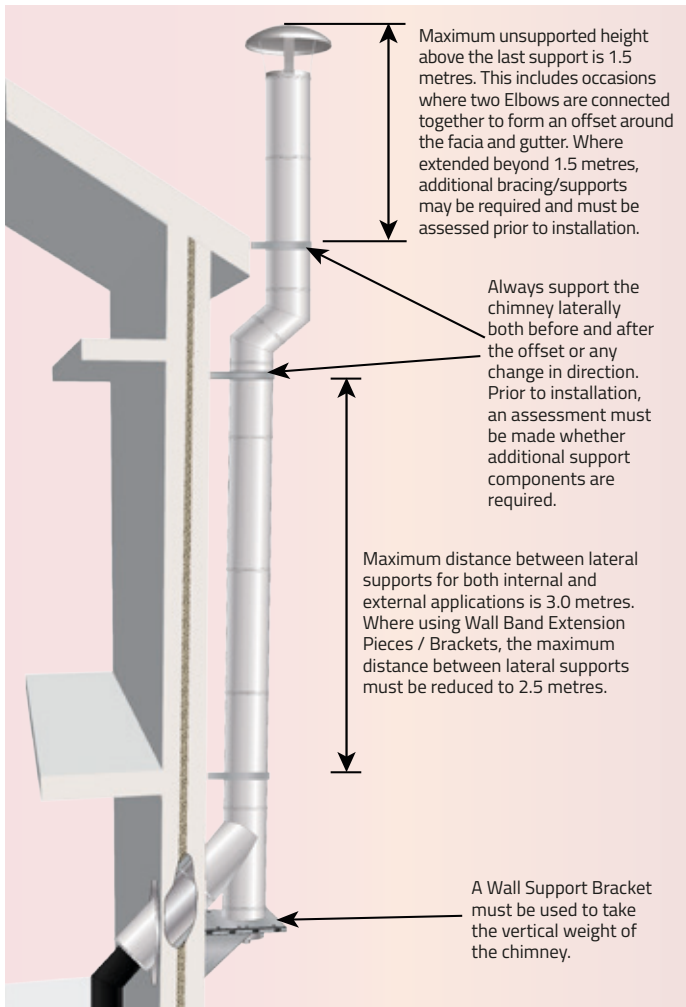

## Wall Band Assembly

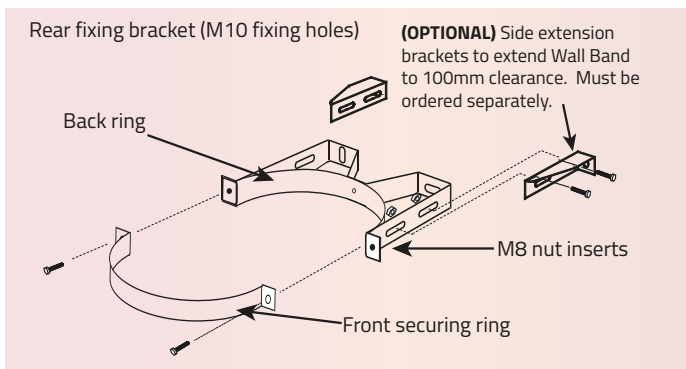

## Combustible floor penetration (>250°C)

Where the chimney system is used with appliances producing flue gas temperatures exceeding 250°C, and where the chimney passes through a combustible floor, the following ventilated components must be used. All floor penetration components are designed to be secured to a pre-built frame construction and lined with a 30 minute fire resistant board to the dimension detailed in the table opposite.

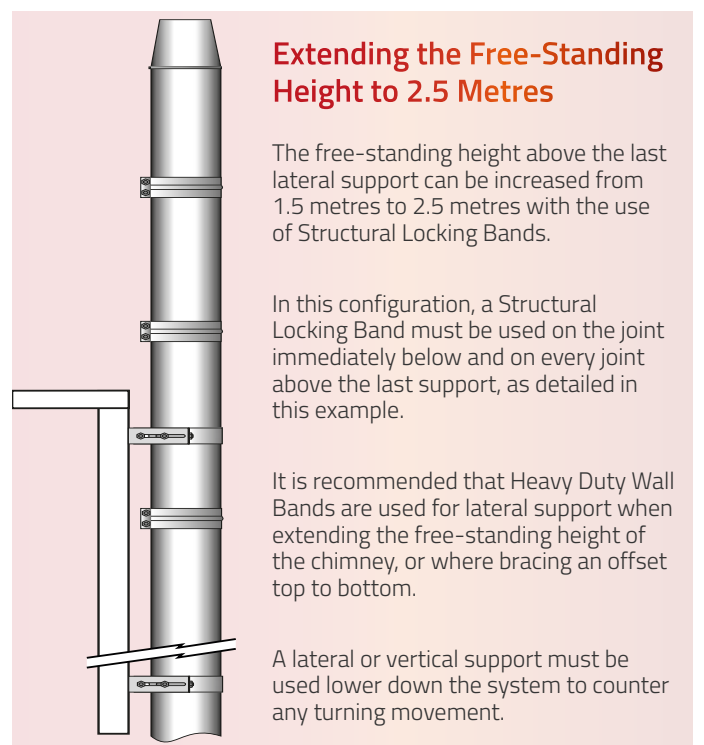
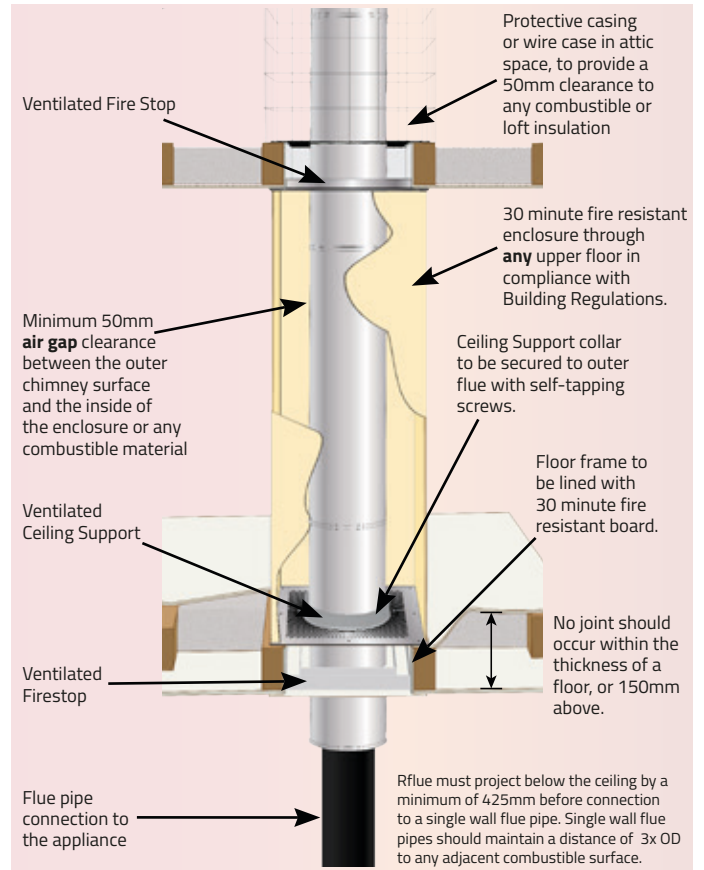

# Installation Guidelines

## Ventilated Ceiling Support and Ventilated Firestop

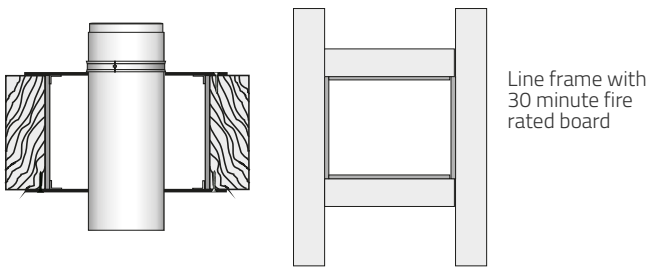

Note: The fire rated board is required under the test conditions of BS 476: Part 20 where the chimney passes through a representative combustible floor. The purpose is to protect the ceiling void from the effects of radiated heat from the outer case of the chimney when the chimney below the ceiling is engulfed in fire.

### Framing data and dimensions

Chimney Size (mm)	127	152
'A' Square*	281	301

\* The above dimension does not allow for 30 minute fire rated lining, adjust according to thickness used.

## Elbow offset dimensions

This data relates to just two elbows used to form an offset as shown below. It also indicates the installed length of the elbow segments. Data is also provided where standard lengths are incorporated within the offset below.

Ø	15°			30°			45°		
	A	B	C	A	B	C	A	B	C
127	87	342	45	87	325	87	87	297	123
152	92	362	48	92	343	92	92	314	130

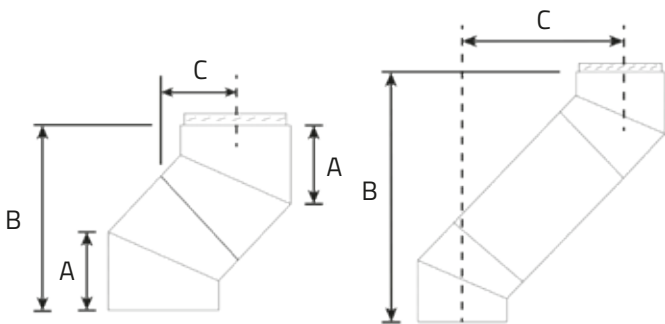

Elbows are not load bearing. Vertical runs after changes of direction should be re-supported appropriately.

### Offset dimensions with standard lengths(mm)

Ø	120mm length						300mm length					
	15°		30°		45°		15°		30°		45°	
	B	C	B	C	B	C	B	C	B	C	B	C
127	457	76	429	147	382	208	631	123	584	237	509	335
152	478	79	447	152	399	215	651	125	603	242	526	342

Ø	500mm length						1000mm length					
	15°		30°		45°		15°		30°		45°	
	B	C	B	C	B	C	B	C	B	C	B	C
127	825	174	758	337	651	476	1308	304	1191	587	1004	830
152	844	177	776	342	668	484	1328	306	1209	592	1021	837

## General

1. Installation of Rflue components must be in accordance with local Building Regulations and associated National Standards and Codes of Practice.
2. Every chimney section and fitting must be used as manufactured, and assembled without any alteration or cutting. Components are joined with a multi barbed twist lock coupler and secured with a Locking Band. The exceptions to this are Elbows and the branch of a 135° Tee, which are designed to allow full rotation of the component and therefore do not have locking barbs on the female end. All components must be installed with the male coupler facing up.
3. The internal diameter of the chimney must conform to the requirements of the appliance manufacturers instructions and should not, under any circumstances, be less than the diameter of the appliance outlet unless operational requirements of the appliance and chimney can be demonstrated by calculations to BS EN 13384-1.
4. The total height of the chimney will depend on the building structure and surrounding environment, however a height of 4.5 metres from the top of the appliance outlet to termination is considered the minimum for solid fuel. Throughout its height, the chimney should remain as straight as possible.
5. It is recommended that a vertical run of at least 600mm should be allowed immediately above the appliance, before a change of direction. Where single wall connecting flue pipe is used directly off of the appliance, it is recommended that the total length is no greater than 2 metres, to avoid excessive cooling of the flue gases. The joint between the single wall connecting flue pipe and the product must be a minimum 425mm below the ceiling in accordance with BS EN 15287-1.
6. Although components are included that will permit horizontal application, they should only be used for connection to the appliance. When connected to a rear outlet appliance, the maximum horizontal distance should be no more than 150mm. It is possible to extend the horizontal length to a maximum of 450mm when meeting the full requirements of BS EN 15287-1. When passing through a wall where the structure or in fill is combustible, the distance to combustible must be increased to 100mm.
7. No part of the chimney system should be constructed to form an angle greater than 45° from the vertical.
8. Offsets can be constructed using Elbows, Lengths and Adjustable components available within the system. Within a system, for all fuels, there should be no more than four changes of direction of 45°. Factory made 90° elbows or tees within the system may be treated as being equal to two 45° elbows. Where an offset is used, the length of chimney between the two elbows must not exceed 20% of the total vertical length of the chimney.
9. Under no circumstances must there be a joint within the thickness of any floor space, or 150mm above the floor line. Where passing through a cavity wall, a wall sleeve must be used and finished with a suitable trim collar / angled cover ring. Note that a wall sleeve does not guarantee the required distance to combustible, this must be assessed during installation.
10. Except for the room containing the appliance, the chimney must be enclosed as per Building Regulations where the chimney passes through any part of the building, where there is a risk of accidental human contact, i.e a bedroom etc., or where there is a risk of contact with combustible materials, e.g a cupboard or in the roof space. This can be achieved by enclosing the chimney within a non-combustible enclosure in habitual rooms etc., or using a protective wire mesh frame in roof spaces etc. In all cases the minimum distance to combustible material must be maintained. Any enclosure should be ventilated using the appropriate Ventilated Firestop components.
11. It is important when passing through lower and upper floors that the correct firestop components are used and the required distance to combustible material is observed. When used on solid fuel or oil-fired appliance where the flue gas is greater than 250°C, always use the Ventilated Ceiling Support and Ventilated Firestops when passing between the lower and upper floors.

# About R W Knight & Son

R W Knight and Son's stoves and fires business is underpinned by our core values of service, reliability and integrity. Based at the family farm, we've been serving Bath, Bristol, Chippenham and the surrounding community for over 45 years, supplying over 40,000 woodburning stoves in that time.

Founder Dick Knight was one of the first farmers to diversify in the 1970s – and it happened almost by accident. His quest to find out more about a 16th century farm building led him to set up a small on-site museum (now closed) to exhibit medieval and stone age artefacts discovered on the farm and locally. Farmers Weekly magazine found out about it and wrote an article about the museum. Included in this article was a photo of Dick's wife Mary, all snug and cosy beside her woodburning stove in the farmhouse.

Readers wanted to find out more, so one of the earliest known articles on woodburning stoves appeared in a follow up Farmers Weekly article in early 1975. As a result, the journalist was inundated

with enquiries from readers wanting to know where they could buy a stove like Mary's and the rest, as they say, is history!

Mary and Dick invited potential customers into their home initially, gradually developing the business. Henry, Dick's son joined in 1978 when he left school.

As the expertise and in-depth knowledge of the products and the industry grew, so did the business. We now have one of the largest showrooms in the South West, still on the farm, but in our Cotswold stone barn. Henry now runs the business with the help of his wife and their 2 children. With Dick still being involved, it continues to be very much a family affair. We are aided by a team of local people, still working from our picturesque farm North of Bath. All of us share a commitment to giving our customers and installers the best possible service and advice providing only the best quality products at a fair price. A warm welcome awaits you.



## RW Knight & Son

Castle Farm  
Marshfield  
Chippenham  
Wiltshire SN14 8HU



## Opening Hours:

Monday-Saturday	9am-5pm
Sunday	Closed
Bank Holidays	Closed

01225 891469

[enquiries@knight-stoves.co.uk](mailto:enquiries@knight-stoves.co.uk) | [www.knight-stoves.co.uk](http://www.knight-stoves.co.uk)